



STUDENT PACKET

GRADES 6-8

The Barn

Avi

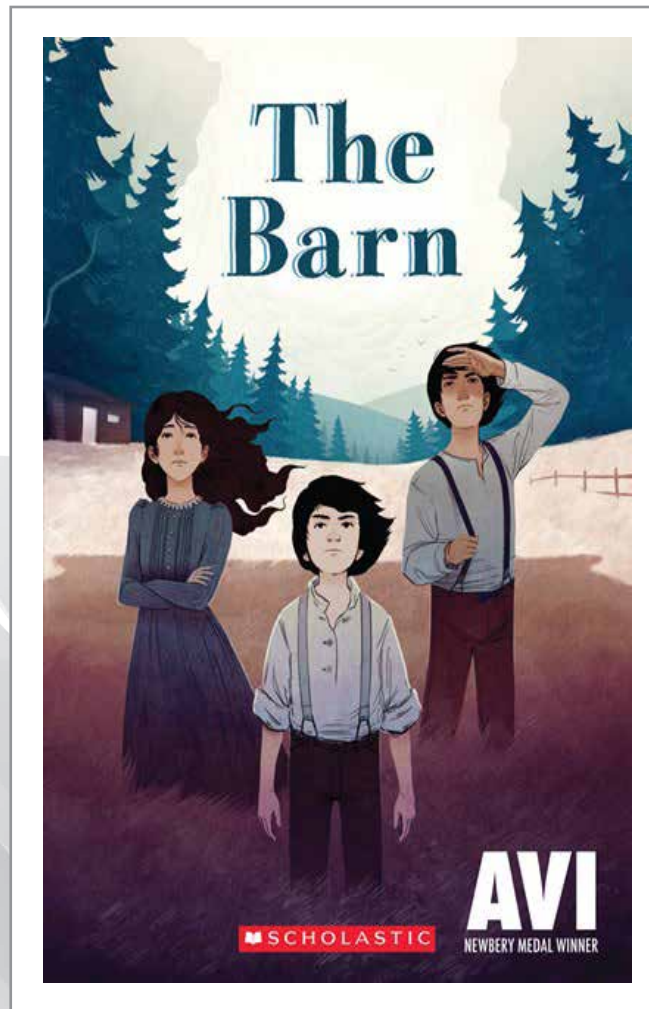

READ, WRITE, THINK, DISCUSS AND CONNECT

The Barn

Avi

STUDENT PACKET

NOTE:

The trade book edition of the novel used to prepare this guide is found in the Novel Units catalog and on the Novel Units website. Using other editions may have varied page references.

Please note: We have assigned Interest Levels based on our knowledge of the themes and ideas of the books included in the Novel Units sets, however, please assess the appropriateness of this novel or trade book for the age level and maturity of your students prior to reading with them. You know your students best!

ISBN 978-1-50204-396-2

Copyright infringement is a violation of Federal Law.

© 2020 by Novel Units, Inc., St. Louis, MO. All rights reserved. No part of this publication may be reproduced, translated, stored in a retrieval system, or transmitted in any way or by any means (electronic, mechanical, photocopying, recording, or otherwise) without prior written permission from Novel Units, Inc.

Reproduction of any part of this publication for an entire school or for a school system, by for-profit institutions and tutoring centers, or for commercial sale is strictly prohibited.

Novel Units is a registered trademark of Conn Education.

Printed in the United States of America.

To order, contact your
local school supply store, or:

Toll-Free Fax: 877.716.7272

Phone: 888.650.4224

3901 Union Blvd., Suite 155

St. Louis, MO 63115

sales@novelunits.com

novelunits.com

Name _____

Pre-reading Research on the Setting

Directions

Fill in this chart with facts about the **time** and **place** of the novel. Then make some predictions about *The Barn*.

Oregon Territory →

FACTS & SOURCE	PREDICTIONS
1.	1.
2.	
3.	2.
4.	
5.	3.

Spring 1855 →

1.	1.
2.	
3.	2.
4.	
5.	3.

Name _____

Directions

Sort the vocabulary words you've seen into categories to help you remember them. You may choose whatever categories you like. Here are a few suggestions to get you started: *new or unfamiliar tools, actions, descriptive words, nouns for feelings...*

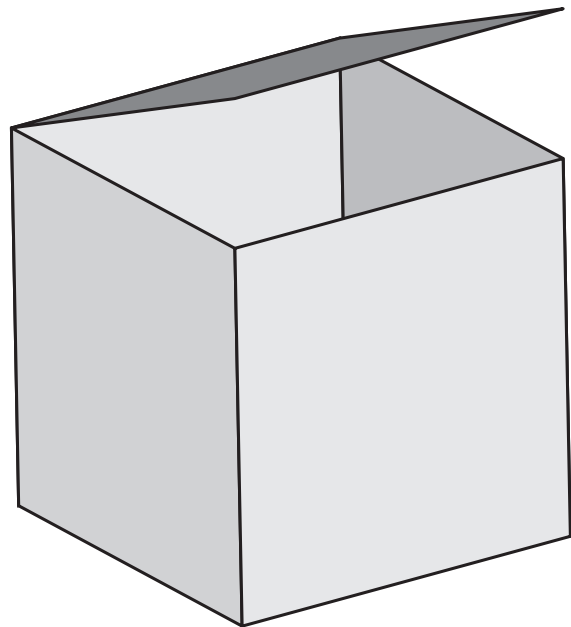
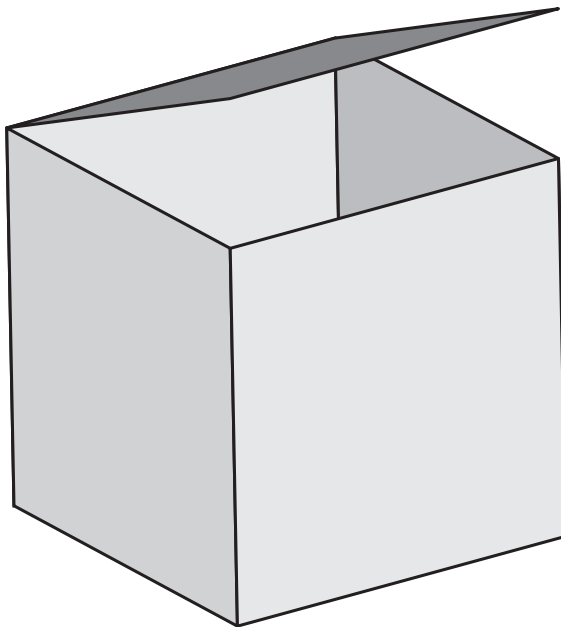
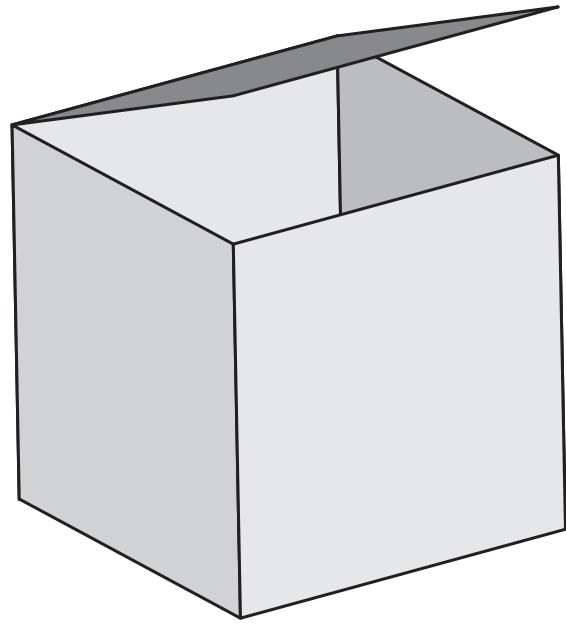
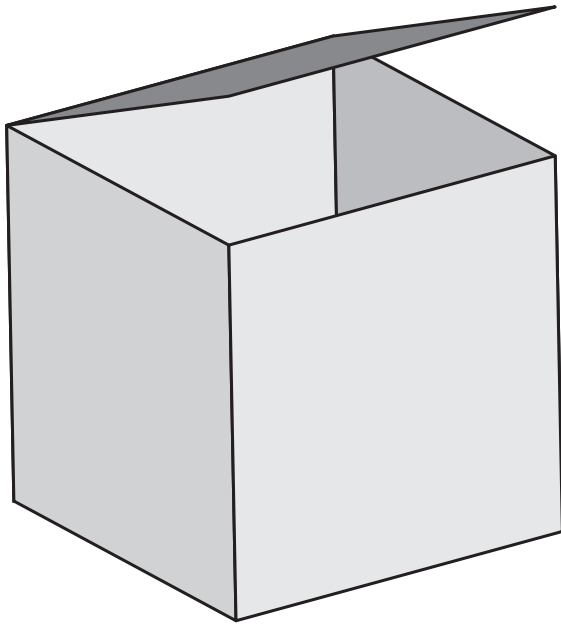

Name _____

Book Honors

Identify each of these book honors listed on the back cover of *The Barn*.



***Booklist* Editor's
Choice**

How often declared?
Honoring group:
Other books so honored:



ALA Notable Books

How often declared?
Honoring group:
Other books so honored:



***American Bookseller*
Pick of the Lists**

How often declared?
Honoring group:
Other books so honored:



***Chicago Tribune*
Best Book for Young
Readers**

How often declared?
Honoring group:
Other books so honored:

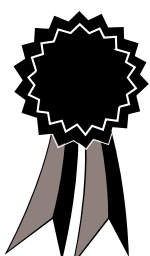

***Teacher's Choice* 1995**

How often declared?
Honoring group:
Other books so honored:

Name _____

Directions

Here are a series of comparisons. Choose one of the book's characters to analyze using at least **five** of the comparisons. State which option the character would, in your opinion, prefer and then tell why.

Character: _____

- breakfast or dinner?
- rock band or string quartet?
- Niagara Falls or Mt. Saint Helens?
- fire or water?
- a mountain or a valley?
- a screened patio or a picture window?
- "a stitch in time..." or "better late than never"?
- the tortoise or the hare?
- a babbling brook or a placid lake?
- a fly swatter or fly-paper?
- a motorcycle or a tricycle?